

## WIRING DIODES FOR MULTIPLE DOOR TRIGGERS

### NOTE:



On many newer vehicles, the dome light has a delay, meaning that the dome light stays on for 30-60 seconds after the last door is closed. This can pose problems on some alarm installations. Most aftermarket alarms will give an error chirp after arming because of the delayed dome light. To avoid the dome light delay, individual door trigger wires must be found. Locate the door trigger wire for each door and then diode isolate, following the appropriate diagram.

- ▶ For vehicles with a door trigger wire for the driver's door and the passenger door(s) wire as shown:

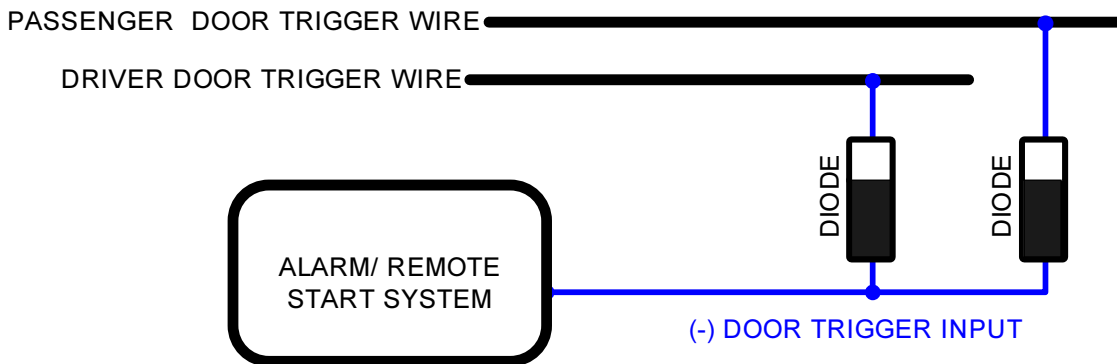

- ▶ For vehicles with a door trigger wire for the driver's door and the passenger door and the rear doors, wire as shown:

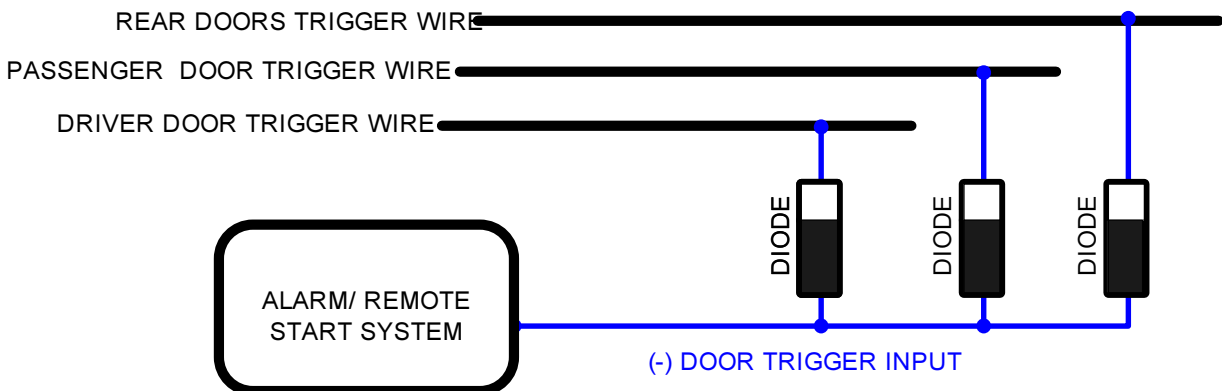



Individual door trigger wires for a 2001 Dodge Caravan are shown. Notice there is a separate door trigger for each of the front doors, the two sliding doors, and the rear hatch.

- ▶ For vehicles with a door trigger wire for the driver's door, the front passenger door, the left rear door, and the right rear door, wire as shown:

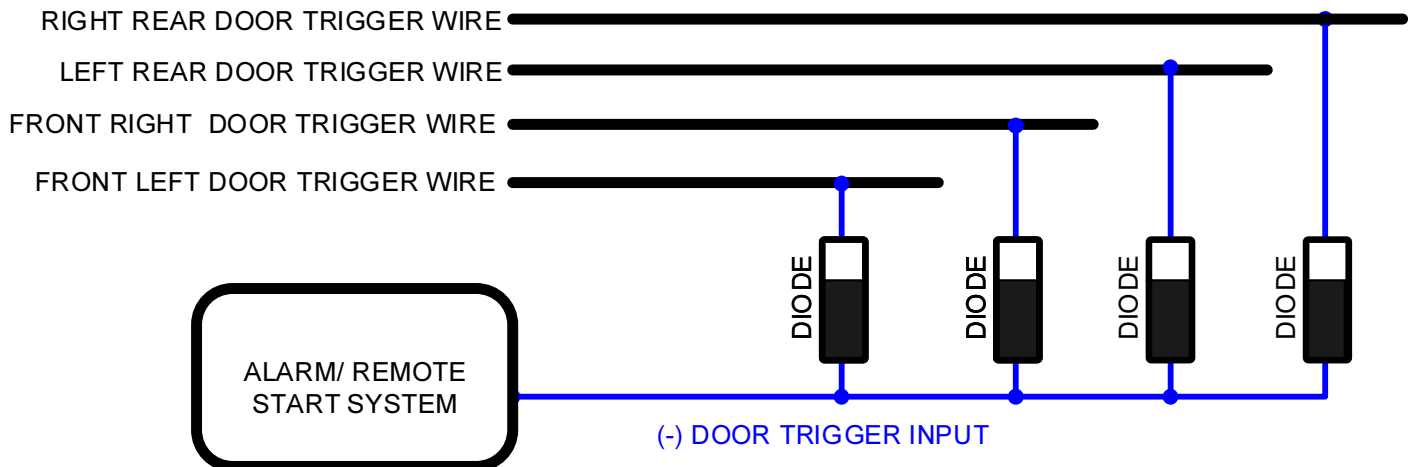

Remote starter and security installations should be attempted by experienced security installers only. Information contained is accurate to the best of our knowledge and experience. Information contained is without any representation of warranty. It is the installer's responsibility to test and confirm all circuits with a digital multi-meter. Proper installation remains the responsibility of the installer. CarInstallExperts.com assumes no liability or responsibility resulting from an improper installation, even in reliance with the information contained in this guide.

- ▶ In some vehicles (generally, newer American vehicles such as Ford, Dodge, and Chrysler vehicles) the vehicle “powers down” various computers in the vehicle to conserve power. This will cause the alarm to false as it senses a drop in voltage and mistakes it for a door being opened. To prevent this, a relay must be used.

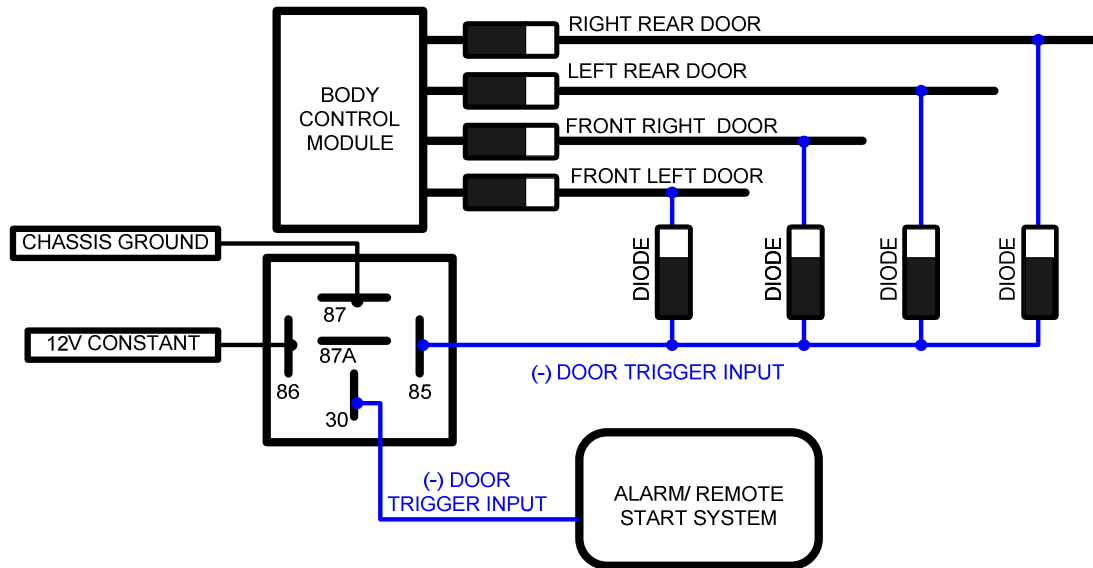

PIN	CONNECTION
85	TO INDIVIDUAL DOOR TRIGGER WIRES THROUGH DIODES
86	12V CONSTANT
87	TO CHASSIS GROUND
87A	NO CONNECTION
30	TO (-) DOOR TRIGGER INPUT ON ALARM SYSTEM

Remote starter and security installations should be attempted by experienced security installers only. Information contained is accurate to the best of our knowledge and experience. Information contained is without any representation of warranty. It is the installer's responsibility to test and confirm all circuits with a digital multi-meter. Proper installation remains the responsibility of the installer. CarInstallExperts.com assumes no liability or responsibility resulting from an improper installation, even in reliance with the information contained in this guide.